

R-2 RESIDENTIAL ZONE - SINGLE-FAMILY

BULK REQUIREMENT DESCRIPTION	REQUIRED/ALLOWED	EXISTING	PROPOSED
MIN. LOT AREA	15,000 S.F.	15,152 S.F.	NO CHANGE
MIN. LOT WIDTH	100 FT.	118.7 FT.	NO CHANGE
MIN. LOT DEPTH	135 FT.	138.4 FT.	NO CHANGE
MIN. FRONT YARD	40 FT.	40.3 FT.	NO CHANGE
MIN. REAR YARD	50 FT.	50.7 FT.	NO CHANGE
MIN. SIDE YARD LEFT	23.7 FT.	32.9 FT.	NO CHANGE
MIN. SIDE YARD RIGHT	23.7 FT.	10.9 FT.	NO CHANGE
MAXIMUM COVERAGE			
IMPERVIOUS	25% (3,788 S.F.)	39.45% (5,977 S.F.)	37.6% (5,692 S.F.)
PRINCIPAL STRUCTURE	12.5% (1,894 S.F.)	17.1% (2,592 S.F.)	NO CHANGE

COVERAGE CALCULATIONS

	EXISTING	CHANGE	EXISTING
HOUSE	2,592 S.F.	NO CHANGE	2,592 S.F.
SHED	66 S.F.	NO CHANGE	66 S.F.
FRONT WALKS/STEPS	433 S.F.*	NO CHANGE	433 S.F.*
REAR WALK/PATIO	1,459 S.F.*	NO CHANGE	1,459 S.F.*
PAVED DRIVEWAY	1,427 S.F.	CONVERT TO PAVERS	1,142 S.F.*
TOTAL COVERAGE	5,977 S.F.		5,692 S.F.

NOTES:

- THIS PLAN IS BASED UPON AN ACTUAL FIELD SURVEY PERFORMED ON NOVEMBER 19, 2019. IF THIS PLAN DOES NOT HAVE A RAISED SEAL, IT IS NOT AN OFFICIAL COPY AND THE SITE MAY HAVE CHANGED SINCE THE DATE OF THE FIELD SURVEY.

PLOT PLAN

PREPARED FOR:
58 UNION HILL ROAD

TAX LOT 12 IN BLOCK 4805

BOROUGH OF MADISON

MORRIS COUNTY NEW JERSEY

Date: 12/09/19

Job No.: 19068

Scale 1 Inch = 20 Feet



ABC SURVEYS, LLC

PROFESSIONAL LAND SURVEYING AND ENGINEERING
466 SOUTHERN BOULEVARD
CHATHAM, NEW JERSEY 07928
VOICE 973-377-2174 FAX 973-377-5533

ANDREW B. CLARKE-PLS, PE

NJ PROFESSIONAL ENGINEER AND LAND SURVEYOR LICENSE No. GB04105600

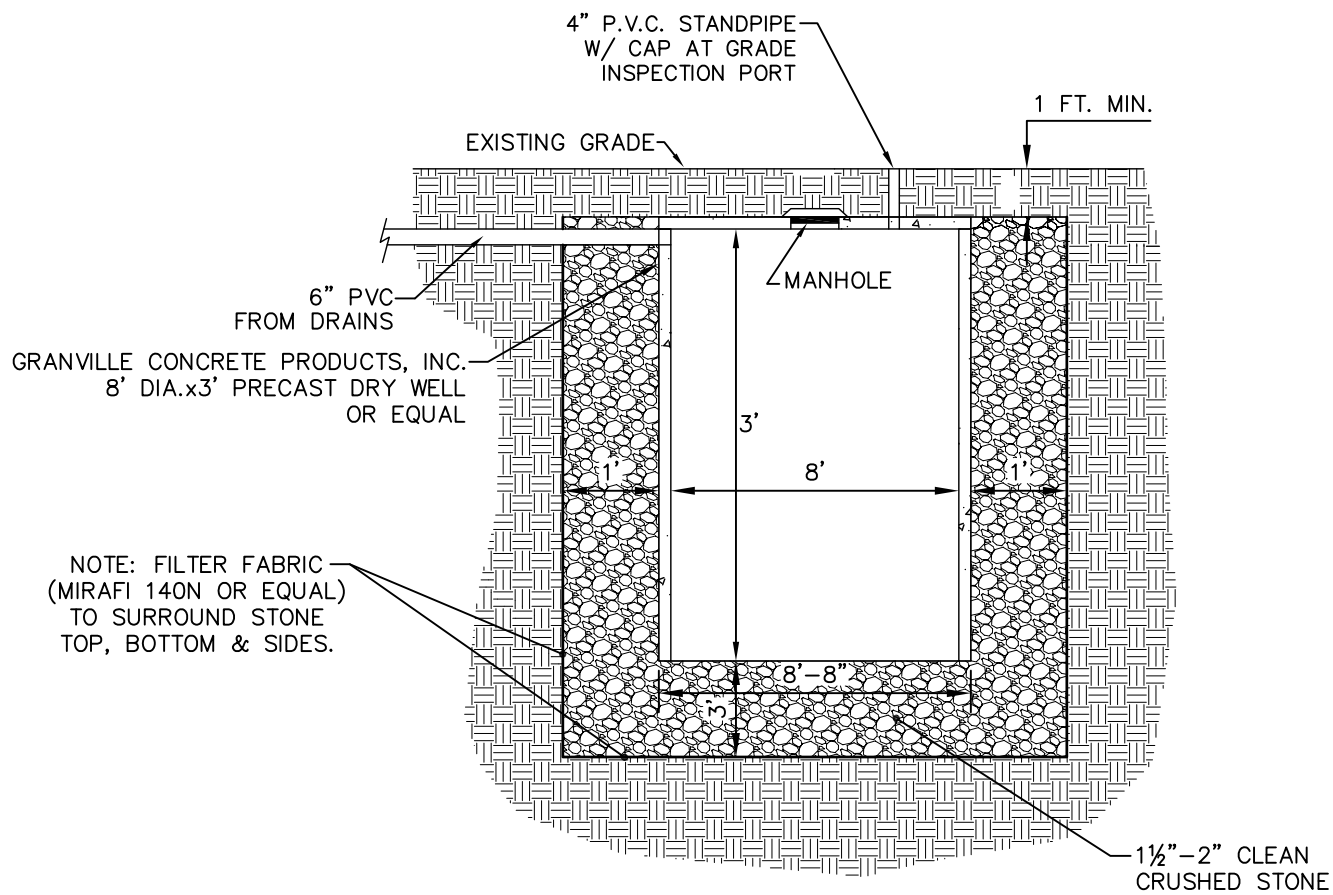

DRY WELL DETAIL

SCALE N.T.S.

DRY WELL DESIGN

CAPTURED PATIO AREA = 1,400 FT.² ±

REQUIRED STORAGE:

$$(1,500 \text{ FT.}^2) \times (3/12) = 350 \text{ FT.}^3$$

STORAGE PROVIDED:

USING ONE 8' DIA.x3' HIGH TANK + STONE w/ 40% VOID RATIO

$$\text{TANK} - (3.14)(4^2)(3) = 150 \text{ FT.}^3$$

$$\text{STONE} - (0.4) [(10.67 \times 10.67 \times 6) - 150] = 213 \text{ FT.}^3$$

$$\text{TOTAL STORAGE PROVIDED} = 363 \text{ FT.}^3 > 350 \text{ FT.}^3 \text{ -OK}$$

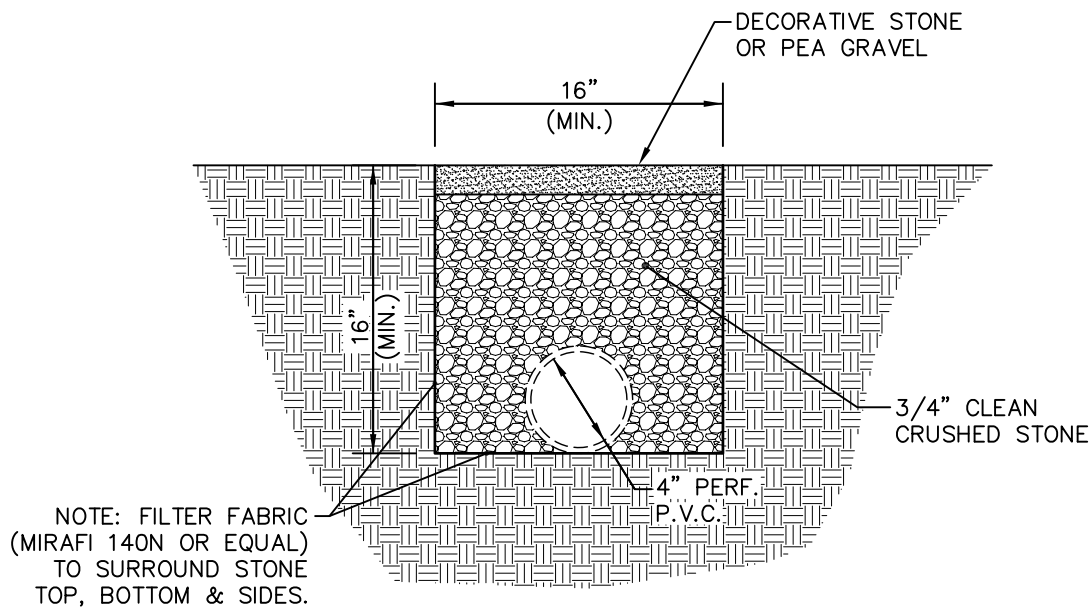

INFILTRATION DRAIN DETAIL

SCALE N.T.S.

STORMWATER MANAGEMENT DETAILS

PREPARED FOR:

58 UNION HILL ROAD

TAX LOT 12 IN BLOCK 4805

BOROUGH OF MADISON

MORRIS COUNTY NEW JERSEY

Date: 12/09/19

Job No.: 19068

Scale 1 Inch = 20 Feet



ABC SURVEYS, LLC

PROFESSIONAL LAND SURVEYING AND ENGINEERING

466 SOUTHERN BOULEVARD
CHATHAM, NEW JERSEY 07928
VOICE 973-377-2174 FAX 973-377-5533

ANDREW B. CLARKE-PLS, PE

NJ PROFESSIONAL ENGINEER AND LAND SURVEYOR LICENSE No. GB04105600